



## Series P

**Heavy Duty Parallel Shaft and Right Angled Gearboxes built to order**

The largest in the gearbox range, the robust Series P gearboxes have a modular construction enabling short leadtimes. They are available in multiple reduction gear stages, having a maximum output torque range of up to 900,000Nm.

### Benefits

- > Available as:
  - Parallel shaft helical gearboxes
  - Right angle bevel-helical units
- > Versatile mounting positions
- > Motorised or reducer options
- > Hollow bore or output shaft mounting
- > Ratios up to 50,000:1
- > Designed and built to order

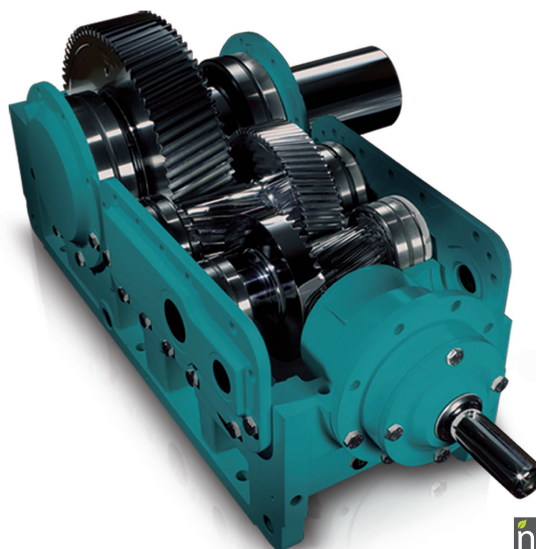

### Size Reference

Ratios up to 50,000:1 up to 900,000Nm

### Construction

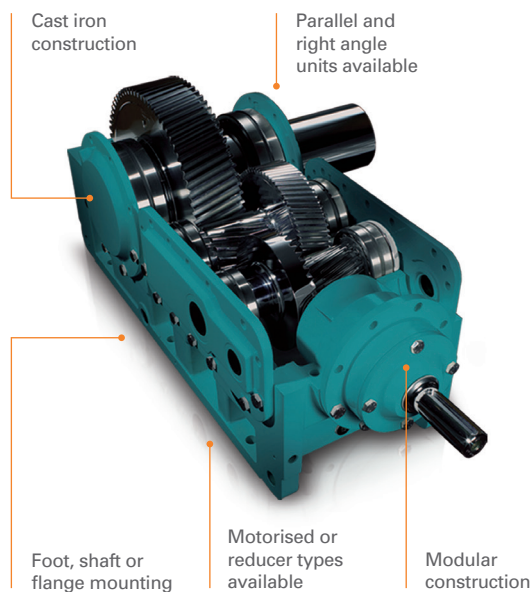

# Fenner®

Reliable | Trusted | Connected